

PCT

WORLD INTELLECTUAL PROPERTY ORGANIZATION
International Bureau



INTERNATIONAL APPLICATION PUBLISHED UNDER THE PATENT COOPERATION TREATY (PCT)

<p>(51) International Patent Classification ⁶ : B01L 3/00, G01N 33/543</p>	<p>A1</p>	<p>(11) International Publication Number: WO 98/15356 (43) International Publication Date: 16 April 1998 (16.04.98)</p>
<p>(21) International Application Number: PCT/GB97/02708 (22) International Filing Date: 8 October 1997 (08.10.97) (30) Priority Data: 9620934.1 8 October 1996 (08.10.96) GB (71) Applicant (for all designated States except US): MOLECULAR DRIVES LIMITED [GB/GB]; University of Glasgow, 2 The Square, Glasgow G12 8QQ (GB). (72) Inventor; and (75) Inventor/Applicant (for US only): GORDON, John, Francis [GB/GB]; 5 Park Crescent, Torrance, Glasgow G64 4BH (GB). (74) Agents: McCALLUM, William, Potter et al.; Cruikshank & Fairweather, 19 Royal Exchange Square, Glasgow G1 3AE (GB).</p>	<p>(81) Designated States: AL, AM, AT, AU, AZ, BA, BB, BG, BR, BY, CA, CH, CN, CU, CZ, DE, DK, EE, ES, FI, GB, GE, GH, HU, ID, IL, IS, JP, KE, KG, KP, KR, KZ, LC, LK, LR, LS, LT, LU, LV, MD, MG, MK, MN, MW, MX, NO, NZ, PL, PT, RO, RU, SD, SE, SG, SI, SK, SL, TJ, TM, TR, TT, UA, UG, US, UZ, VN, YU, ZW, ARIPO patent (GH, KE, LS, MW, SD, SZ, UG, ZW), Eurasian patent (AM, AZ, BY, KG, KZ, MD, RU, TJ, TM), European patent (AT, BE, CH, DE, DK, ES, FI, FR, GB, GR, IE, IT, LU, MC, NL, PT, SE), OAPI patent (BF, BJ, CF, CG, CI, CM, GA, GN, ML, MR, NE, SN, TD, TG).</p> <p>Published <i>With international search report. Before the expiration of the time limit for amending the claims and to be republished in the event of the receipt of amendments.</i></p>	

(54) Title: APPARATUS AND METHOD FOR CONDUCTING ASSAYS

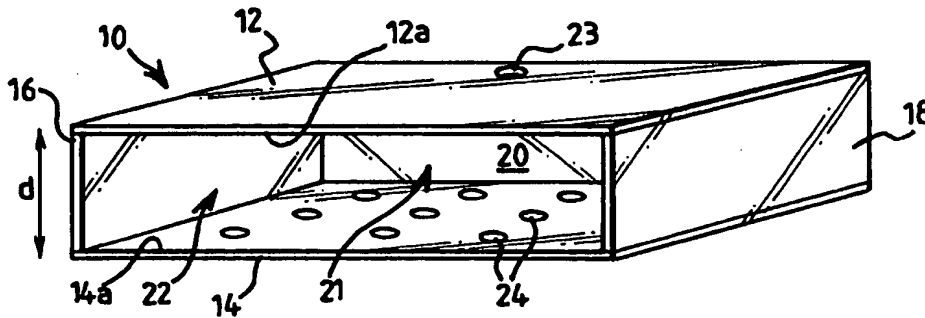

(57) Abstract

A multi-well assay plate structure (54) and assay apparatus and a method for performing chemical biochemical assays is described. The multi-well assay plate structure (54) defines a relatively shallow substantially enclosed space (71) above a plurality of wells (76), with the enclosed space (71) having an inlet (72) and an outlet (22) separate from the inlet. Fluid introduced via the inlet (72) flows into the space (71) and/or wells (76) by displacing air. Withdrawal of the fluid via the inlet (72) or outlet leaves fluid in the wells (76) allowing various tests to be performed. Various embodiments of the structure are described. The preferred arrangement embodies the structure on a transparent plastic disk which can be used with automatic fluid handling apparatus (80) and the results assessed using optical assessment apparatus (81). The apparatus can be used to perform a variety of assays but, in particular, biochemical/chemical assay, immunoassays and genetic (DNA) assays and it can be used in a laboratory for multiple sample testing or at a point-of-care, i.e. in a surgery or clinic.

FOR THE PURPOSES OF INFORMATION ONLY

Codes used to identify States party to the PCT on the front pages of pamphlets publishing international applications under the PCT.

AL	Albania	ES	Spain	LS	Lesotho	SI	Slovenia
AM	Armenia	FI	Finland	LT	Lithuania	SK	Slovakia
AT	Austria	FR	France	LU	Luxembourg	SN	Senegal
AU	Australia	GA	Gabon	LV	Latvia	SZ	Swaziland
AZ	Azerbaijan	GB	United Kingdom	MC	Monaco	TD	Chad
BA	Bosnia and Herzegovina	GE	Georgia	MD	Republic of Moldova	TG	Togo
BB	Barbados	GH	Ghana	MG	Madagascar	TJ	Tajikistan
BE	Belgium	GN	Guinea	MK	The former Yugoslav Republic of Macedonia	TM	Turkmenistan
BF	Burkina Faso	GR	Greece	ML	Mali	TR	Turkey
BG	Bulgaria	HU	Hungary	MN	Mongolia	TT	Trinidad and Tobago
BJ	Benin	IE	Ireland	MR	Mauritania	UA	Ukraine
BR	Brazil	IL	Israel	MW	Malawi	UG	Uganda
BY	Belarus	IS	Iceland	MX	Mexico	US	United States of America
CA	Canada	IT	Italy	NE	Niger	UZ	Uzbekistan
CF	Central African Republic	JP	Japan	NL	Netherlands	VN	Viet Nam
CG	Congo	KE	Kenya	NO	Norway	YU	Yugoslavia
CH	Switzerland	KG	Kyrgyzstan	NZ	New Zealand	ZW	Zimbabwe
CI	Côte d'Ivoire	KP	Democratic People's Republic of Korea	PL	Poland		
CM	Cameroon	KR	Republic of Korea	PT	Portugal		
CN	China	KZ	Kazakstan	RO	Romania		
CU	Cuba	LC	Saint Lucia	RU	Russian Federation		
CZ	Czech Republic	LI	Liechtenstein	SD	Sudan		
DE	Germany	LK	Sri Lanka	SE	Sweden		
DK	Denmark	LR	Liberia	SG	Singapore		
EE	Estonia						

APPARATUS AND METHOD FOR CONDUCTING ASSAYS

The present invention relates to apparatus and to a method for conducting assays and, in particular, to multi-well plate structures for receiving and holding, in separate wells, volumes of liquid for the purpose of conducting chemical or biochemical assays. Multi-well trays or plates having a 2-dimensional array of small wells are commonly used in medicine and science to facilitate testing of a liquid analyte. One particular area of use is blood screening where blood or blood products are introduced into the wells to test for viruses such as HIV, hepatitis etc.

Such tests (immunoassays) typically involve an antigen-antibody interaction, where the surfaces of the wells are coated with specific antigen itself. This approach detects circulating antibodies to that specific antigen. Alternatively the wells can be coated with a specific antibody which captures circulating antigen which is, in turn, identified by a second antibody directed against a second epitope on the captured antigen. These two approaches are just two of the large number of variants developed in immunoassay (review Principles and Practice of Immunoassay Price & Newman 1997 ISBN 1-56159-145-0).

In an immunoassays sample must be applied and in most cases subsequent addition of reagents or washing buffer is required. Typically the well is exposed to blood or blood product and the well is rinsed clean and a further reactant, which binds either to exposed antibodies or captured antigens is introduced into the wells, to create an observable reaction. These reactions may produce a colour or some other observable change. This enables the wells containing specific antigen antibody reactions to be identified and the extent of these reactions quantified.

It is often necessary to fill each well of a multi-well tray with a precisely defined volume of analyte. This is normally achieved using a single or multi-headed micro-

pipette. However, this process is often time consuming and, particularly where a large number of wells are to be filled, can lead to a number of wells being missed.

5 In certain circumstances it is necessary that the wells of a tray be contained within a substantially closed container, e.g. to avoid the risk of contamination of the wells and of leakage of contaminated material. With trays such as this, it may be difficult or impossible to gain access to the wells to enable them to be filled using a
10 micro-pipette.

It is an object of the present invention to overcome or at least mitigate the disadvantages of known multi-well trays.

15 This is achieved by providing a multi-well assay plate structure which defines a relatively shallow substantially enclosed space above a plurality of wells, with the enclosed space having an inlet and an outlet separate from the inlet. Fluid introduced via the inlet flows into the space, and covers the wells, by displacing air.
20 Withdrawal of the fluid from the space via the inlet or outlet leaves fluid in the wells allowing various tests to be performed.

According to a first aspect of the present invention there is defined a multi-well assay plate structure
25 comprising:

a first upper surface,
a second lower surface having a plurality of wells disposed therein,
30 the first and second surfaces defining a chamber having an inlet and an outlet, the inlet and outlet allowing fluid to be introduced and withdrawn from the chamber, the wells being proportioned and dimensioned to retain a volume of fluid in each well following withdrawal of the liquid.

35 Preferably, the chamber is shallow enough to allow fluid to fill the wells and the chamber. The wells are deep enough to retain a volume of fluid following

withdrawal of fluid in the space above the wells.

The plate structure can be of any convenient shape but, advantageously, is sector-shaped with a detachable handle at the longer arc-portion to facilitate locating the sector on a disc. Conveniently, a plurality of sector-shaped structures are located on the disc.

Conveniently, also the sectors and discs are made of plastic and the sectors can be snap-fitted onto the disc. The sectors and the disc include lock and key portions to allow the sectors to be snap-fitted in the correct orientation only.

Alternatively, a disc with a plurality of separate sections can be manufactured or moulded in one piece instead of snap-in sectors.

The composite structure may be snap-fitted onto a compact disk.

The disk structure may have a circumferential gutter extending around its periphery to facilitate collection of fluid following fluid introduction/withdrawal from the chamber.

The wells are dimensioned and proportioned in terms of diameter and depth to receive and retain fluid containing the analyte or part of the reagent under test. The exact dimensions are a matter of choice and depend on a number of parameters such as the type of material of the surfaces of the chamber and wells; viscosity of the fluid and the depth (height) of the space between the first and second surfaces.

Advantageously, the dimensions of the structure are such that the wells fill to retain sufficient fluid the space is flooded and withdrawal to allow a measurable reaction to be measured within an individual well without contribution from adjacent wells. The overall process of sequential steps of flood and fill is advantageous in that it allows both discrete measurements within individual wells when filled and efficient washing of an array of wells (flood) which is useful in multistep procedures, such

as immunoassays, which requires sequential application of reagents interspersed with rigorous washing steps. This permits the wells to be cleaned or rinsed in the same way as filling to allow subsequent tests to be carried out within an individual well whilst avoiding cross-contamination between adjacent wells.

The structure is preferably made of transparent or otherwise optically transmissive plastic to facilitate optical reading of the wells to determine the results of the tests. Conveniently, the structure is integrated with automatic fluid handling apparatus and an optical reader to allow automatic fluid handling and optical assessment of the results of the reactions. Alternatively, fluid handling can be manually controlled and the results of the reactions within the structure can be assessed by an optical reader or be scored by visual assessment.

According to a second aspect of the present invention there is provided a multi-well assay structure comprising an upper surface and a lower closely spaced opposed surface, said upper and lower surfaces defining a relatively shallow space therebetween, the lower surface having a plurality of wells therein, at least two spaced apart openings providing access to said space from an external location, wherein a fluid introduced into said space through one of said openings fills substantially all of the space and covers of the wells and said fluid, when subsequently withdrawn through the same or the other opening, leaves the wells filled with liquid.

The volume of fluid introduced into each well when using the structure of the present invention is substantially defined by the volume of the well. The accuracy and precision with which the wells can be filled is therefore defined by the accuracy and precision with which the wells can be fabricated and which is generally high. Furthermore, the multiplicity of wells can be filled by way of a single injection and withdrawal of fluid through an opening into the space containing the wells, so

that the wells can be filled extremely rapidly.

The structure of the present invention provides for the filling of a plurality of wells in a substantially closed chamber, the only openings into that container being the fluid injection opening and a second 'vent' opening.

The structure of the present invention simplifies the process of cleaning or rinsing previously filled wells as this can be achieved by repeatedly injecting and withdrawing fluid through one of said openings.

Conveniently, the spacing between said upper and lower surfaces is sufficiently small to facilitate the flow of fluid in said space by capillary or capillary like action. Typically, the spacing is less than 1mm and preferably less than 0.5mm.

Preferably, said upper and lower surfaces are substantially planer.

The wells may have any suitable geometry. For example, the wells may be provided in said lower surface by blind circular holes with a semi-spherical termination. Alternatively, the wells may have substantially straight sidewalls, e.g. so that the sidewalls extend substantially vertically and terminate in a flat base. Vertical sidewalls assist in preventing the transfer of fluid between adjacent wells.

The surfaces may be provided by respective upper and lower plates which are spaced apart by one or more spacer walls.

Preferably, the opening through which fluid is introduced into said space is provided through either the upper or lower surface and, more preferably, through the upper surface. The additional opening may be provided through said upper or lower surface or through a side surface.

Preferably, said opening for introducing a fluid comprises a relatively small opening arranged to receive the end of a syringe or similar liquid injecting device, where the opening forms a substantially air-tight seal

around said end.

Preferably, said lower surface of the container is treated to increase the hydrophobicity to facilitate smooth flow of liquid across the sector and hydrophilicity to aid movement of liquid into desired locations, e.g. wells. This helps to prevent the formation of air pockets in the space and aids filling of the wells. The treatment may comprise for example exposing the surface to a wetting agent, e.g. poly-l-lysine, or exposing the surface to a gas plasma.

In one embodiment of the present invention, the multi-well structure is embodied in a disc. The disc effectively comprises upper and lower circular plates, the internal surfaces of which respectively define said upper and lower opposed surfaces. Preferably, said opening for introducing liquid into the space is a hole passing through the upper circular plate. Preferably, the second opening is provided at the peripheral edge of the disc. The space between the upper and lower plates is subdivided, by one or more dividing walls, to provide a plurality of multi-well plates in which case each space is provided with an opening and a vent to enable each space to be independently filled. The dividing walls may extend radially and/or may be concentric to one another.

Preferably, at least one of the upper and lower plates forming the container are transparent to enable optical inspection of the wells from outside the container. The other of the upper and lower plates may comprise a reflecting surface so that radiation entering into the container through the transparent plate transverses the container in both directions, resulting in an improved signal detection for optical inspection.

In an alternative embodiment of the present invention there is provided a disc arranged to receive a plurality of sector (pie) shaped inserts each of which comprises a generally planar upper surface having a plurality of wells provided therein. For each insert, the disc comprises a

substantially planar surface arranged, in use, to oppose said substantially planar insert surface and means for retaining the insert in position so that the respective planar surfaces are in closely spaced opposition to one another, and said at least two openings.

5 Preferably, the opening for filling the container is provided through the planar surface of the disc. The vent opening is preferably provided at, or adjacent to, the peripheral edge of the disc.

10 The disc preferably comprises upper and lower circular plates separated by radially extending spacers. The spacers define slots between the plates for receiving said inserts. Preferably, said planar surface of each insert comprises upstanding walls around at least a portion of its periphery for the purpose of sealing the inner edges of the insert to the opposed planar surface of the disc, thereby to prevent seepage of liquid around the insert.

15 According to a third aspect of the present invention there is provided a method of filling the wells of the multi-well structure of the above first aspect of the present invention, said method comprising the steps of:

20 introducing a fluid into said chamber through one of said openings to substantially flood the chamber;
and subsequently withdrawing the fluid from the chamber through the same or the other opening to leave liquid in the wells.

25 Preferably, the method further includes the step of forming an air tight seal between the fluid inlet and an end region of a syringe or similar liquid injecting device, and injecting fluid through the opening into the chamber and subsequently sucking liquid out of the space through the opening.

30 According to a fourth aspect of the present invention there is provided a method of conducting a chemical or biochemical assay said method comprising the steps of:

35 providing a surface within a substantially enclosed chamber having a plurality of wells at spaced locations

sufficient to allow a reaction at each well location,
treating each well with a first reagent, flooding the
enclosed chamber and covering the wells with a fluid
carrying at least a second reagent,

5 removing excess fluid from said chamber to leave a
mixture of said first and second reagents in each well, and
optically assessing each well and determining if a
reaction occurred and correlating the reaction results to
provide an assay of the chemical or biochemical reactions
10 under test.

Preferably, the step of optical assessment is carried
out automatically using optical reading apparatus.

Preferably also, the surfaces with the wells having
first fluid carrying reagents are prior prepared for
15 loading into the structure.

Conveniently, the fluid carrying at least the second
reagent is introduced into the structure and withdrawn from
the structure using suitable automatic fluid handling
apparatus.

20 Conveniently also, after optical assessment of the
results of the assay, the automated fluid handling
apparatus is used to inject and withdraw rinsing fluid a
predetermined number of times from the well tray to clean
the wells for receiving subsequent samples for assay.

25 According to a fifth aspect of the present invention,
there is provided chemical/biochemical assay apparatus
comprising an assay plate structure defined in said first
aspect and having a plurality of wells for receiving
samples to be assayed,

30 fluid handling means for introducing and removing
fluid reagents into said assay plate structure to allow a
fluid reagent mixture to be retained in each well, and
optical assessment means for measuring optical result
of the reaction in each well.

35 Preferably, the fluid handling means and the optical
assessment means are automated.

According to a sixth aspect of the present invention

there is provided an assay plate structure for use in conducting optical assays of a fluid analyte, the plate structure comprising:

5 a disc for rotation about a central axis, the disc having upper and lower plates and a plurality of substantially radially extending walls disposed between the plate, wherein said walls sub-divide the disc into a plurality of disc sectors; and

10 a plurality of disc inserts arranged to be received by respective disk sectors and to be retained therein,

the structure further having a plurality of openings through the upper surface, at least one opening above each disc sector for introducing a liquid analyte into the sector space between the plate and the disc insert.

15 Preferably, the disc further comprises a lower plate, spaced apart from said upper plate by said radially extending walls. More preferably, the upper and lower plates are circular.

20 Preferably, the upper surface of each disc insert and the opposed surface of the plate are substantially planar, and, more preferably, are in a closely spaced arrangement.

Preferably, a vent opening is provided for each disc segment around the periphery thereof, between the radially outer edge of the upper plate and each disc insert.

25 These and other aspects of the present invention will now be described with reference to the accompanying drawings, in which:

30 Fig. 1 is a diagrammatic representation of a multi-well assay plate structure according to a first embodiment of the present invention;

Figs. 2a to 2c illustrate the steps involved in filling the wells of the container of Fig. 1;

Fig. 2d is an enlarged detail of part of the structure of Figs. 2a to 2c;

35 Fig. 3 shows a multi-well assay plate structure according to a second embodiment of the present invention;

Fig. 4a shows a third embodiment of a disc-style

structure for conducting multi-tests;

Fig. 4b shows an enlarged cross-sectional detail of Fig. 4a to allow snap-fitting of the plates in the disc sectors;

5 Fig. 4c is a fourth embodiment of a disc-style structure for conducting multi-tests;

Fig. 4d shows a modification of the outer disc with hinged sectors and which is applicable to the previous embodiments;

10 Fig. 5 depicts chemical/biochemical assay apparatus for conducting an assay on reactions carried out using the multi-well assay plate structures shown in Fig. 3 or Figs. 4a b, c and d, and

15 Figs. 6a and 6b depict the data and graphs respectively of antigen/antibody biochemical assays carried out using the apparatus of Fig. 5 on the assay plate shown in Fig. 4a, b, c and d.

Reference is first made to Fig. 1 which shows a multi-well assay plate, generally indicated by reference numeral 20, having a box-like construction with a rectangular cross-section. The assay plate 10 comprises an upper plate 12, a lower plate 14, and side and rear spacers 16,18,20 all of which are made of a transparent polycarbonate. The front of the box, indicated generally by the reference numeral 22, is open to the surrounding space.

25 The spacers 16,18,20 are dimensioned to produce a space 21 of uniform spacing d between the opposed inner surfaces 12a,14a of the upper and lower plates 12,14. Spacing d is chosen such that a selected liquid is able to flow through the space 21 between the upper and lower plates 12,14 in a controlled manner by capillary or capillary-like action. Generally, d is less than 0.5mm.

30 A small opening 23 extends through the upper plate 12 to communicate the inner space 21 with the exterior space surrounding the container. Opening 23 is located close to the rear wall 20 in order to prevent air-locks forming in the container during filling as will be described in more

35

-11-

detail below.

A regular array of wells or depressions 24 are formed in the upper surface 14a of the lower plate 14. Typically, the polycarbonate assay plate with wells 24 is produced by suitably moulding the lower plate 14 or by etching or pressing. The wells 24 are 2mm in diameter and 1mm deep and typically have a volume of 5 μ l and any suitable number of wells may be provided. The wells are spaced 4mm apart (centre to centre).

Figs. 2a to 2c illustrate the process by which the wells 24 of the assay plate 10 are filled with a liquid analyte 25. The end 26 of a syringe 28 containing the liquid analyte 25 is pressed into the opening 23 provided in the upper plate 12 of the container 10 (Fig. 2a) so as to form an air-tight seal between the periphery of the syringe and the inner surface of the opening 23. The plunger 30 of the syringe 28 is then depressed to force the liquid 25 through the opening 23 into the space 21 within the plate 10. As best seen in Fig. 2b, due to the capillary or capillary like flow of liquid through the space 21, the entire space 21 is filled and wells 24 are covered before liquid 25 begins to flow through the front open face 22 of the container 10. When it is observed that all of the space 21 is filled and the wells 24 are covered with liquid, and preferably prior to liquid flowing out through the front face 22, the plunger 30 of the syringe 28 is withdrawn. This action empties the space 21 of liquid, but results in the wells 24 being filled with liquid 25 as shown in Fig. 2c. Fig. 2d shows an enlarged cross-sectional view through part of the assay plate structure and showing how liquid is retained in wells 24 up to the meniscus. As with the filling process, liquid flows from the space 21 in a controlled manner. No puddles or drops of liquid remain in the space 22, other than in the wells 24.

It will be appreciated that prior to introducing the liquid analyte 25 into the space 21, for example during the

-12-

manufacture of the assay plate 10, the wells 24 of the plate 10 may be coated with an appropriate reactant. For example, if it is desired to conduct antigen-antibody reactions, the wells 24 are coated with an antigen. The remainder of the surface 14a is coated with a blocking agent to prevent antigen and antibodies from binding to surface 14a. Once the wells 24 have been filled with the liquid analyte 25, any antibodies present in the liquid analyte 25 will bind with the antigens contained in the wells 24. There is no binding of the antibodies to surface 14a. If it is necessary to conduct a further reaction in the wells 24, e.g. to bind a coloured or fluorescent label to the bound antibodies or exposed antigens, it is possible to repeat the steps of Figs. 2a to 2c in order to introduce the labelled components into the wells 24. Prior to introducing the labelled components, if it is necessary to rinse the wells 24 and the inner surfaces 12a, 14a of the plate 10, this is again easily achieved by repeating steps 2a to 2c with the syringe 28 containing, for example, distilled water.

There is illustrated in Fig. 3 a second embodiment of the present invention which depicts a multi-well assay plate in the form of a disk 32 designed for use with a rotating scanning device having a CD player type format. One such device is described for example in WO96/09548. The disk 32 shown in Fig. 3 comprises a pair of upper and lower circular plates 34, 36 sandwiched together to provide a cylindrical space 38 therebetween. This space 38 is divided into eight sectors 40 by radially extending spacers 42. A plurality of wells 44 are provided in each sector 40 (one set of which is shown in broken outline) by forming the upper surface 36a of the lower circular plate 36 as described with reference to Fig. 1. The wells 44 are of the same size and are spaced as for Fig. 1.

Each sector 40 provides a chamber or space 46 which can be filled independently via openings 48 provided through the top surface of each sector 40. The peripheral

-13-

edge 50 of each sector 40 is open to the surrounding space to provide a vent for the sector 40 to allow liquid to flow through the space or chamber 46 by displacing air therefrom.

5 In order to enable the disk 32 to be compatible with scanning devices such as are described in WO 96/09548, the upper and/or lower plates 34,36 are made of transparent polycarbonate to enable a light beam to be scanned across the disk surface. The disk 32 is provided with a central
10 hole 52 to enable the disk 32 to be mounted on a rotatable shaft.

As is described in WO 96/09548, one of the surfaces of the upper or lower plates 34,36 may be provided with digitally encoded address information which can be read by
15 the scanned light beam. This information may be encoded by way of "pits" and "lans" pressed or moulded into one of the plates. This address information can be used to provide accurate location information on the part of the disk which is begin scanned by the light beam.

20 There is shown in Fig. 4 a third embodiment of a disk assay plate 54 which comprises upper and lower circular transparent polycarbonate plates 56,58 which are spaced apart by a number of radially extending spacer walls 60 to create a plurality of disk sectors 62. The inner surfaces
25 56a,58a of the circular plates 56,58 are both planar.

Each disk sector 62 is arranged to receive a sector plate insert 64 which is a transparent polycarbonate plate with a detachable handle 66 on the outer side to facilitate entry and removal of the plate insert 64 in the sector 62.
30 The plate insert 64 and spacer wall 60 have respective recesses/projections (not shown in the interest of clarity) which allow the assay plate 64 to be inserted only in the correct orientation. The plate 64 has a groove 68, as shown in Fig. 4b for example, which allow the insert to be
35 snap-fitted over a projection 70 upstanding from plate 58 into the sector. The thickness of the sector insert plate 64 is marginally less than the spacing provided between the

upper and lower plates 56,58 so that the plate insert 64 can be pressed/fitted into one of the disk sector 62 to define a liquid receiving chamber or space 73 between the upper surface 64a of the insert plate 64 and the lower surface 56a of the upper disk plate 56. Openings 72 are provided through the upper plate 56 into each disk sector 64 whilst the space 70 between the radially outermost peripheral edge 74 of the insert plate 64 and the upper plate 56 provides a further vent or filling opening into the disk sector 64.

The surface 64a of the insert plate 64 is provided with a plurality of wells 76 as described with respect to Fig. 1. The wells are 2mm in diameter, 1mm in depth and 4mm apart (spaced between centres). These wells are filled by introducing liquid into the disk sector 64 through the upper opening 72 to fill space 70 and subsequently withdrawing the liquid through the same opening as previously described.

Reference is now made to Fig. 5 of the drawings which depicts assay apparatus for conducting an assay on reactions carried out using the assay plate structures of the already described embodiments. However, for convenience, the assay apparatus will be described in combination with the preferred embodiment shown in Figs. 4a,b with like numerals referring to like parts.

In this case the plate 54 is mounted on a shaft 74 carried by a turntable 77. The apparatus includes a suitable automatic fluid filling/withdrawal system, generally indicated by reference numeral 80, which operates a syringe 82 to dispense/retrieve fluid from a reservoir 84 via the openings 72 into the space 70 between the plate surface 56a and the surface 64a of each sector plate 64. The fluid can of course be dispensed and retrieved manually if desired. This is achieved for each sector by rotating the disk plate 54 to a suitable position to allow fluid filling/withdrawal. It will be appreciated that the plates are pre-prepared with various reagents, e.g.

antigens, and they are inserted in the appropriate wells 76, as described with reference to Figs. 4a,4b. The plates are first flooded with fluid carrying antibodies and withdrawal of the fluid leaves the antibody/antigen reagents filling the wells 76 resulting in a reaction.

The following example of an assay within the embodiment shown in Fig. 4b is described to provide a better understanding of the steps involved:

Multi-Antigen Elisa Using Sectors

1. The underside of upper surface (56a) of is coated with silicone spray to aid fluid movement. Sector plates 64 are also coated including wells 76. Any excess silicone is removed.
2. Sectors wells 76 are loaded by hand with a panel of seven antigens - Human Serum Albumin, Antitrypsin, Macroglobulin, Antithrombin III, Catalase, Antichymotrypsin and Plasminogen at a concentration of 20ug/ml in PBS and a volume of 2ul/well. Control wells contain PBS only. Antigens can be arranged in blocks of the same on the sector plate 64 in a series giving a panel of tests evenly distributed over the sector. Incubate at room temperature for 15 minutes.
3. Wash with 0.05% PBS-Tween using flood/fill technique - 1ml is flooded across the sector plate via holes 72 in the top plate using a 1ml pipette. This pipetted up and down three times then withdrawn and the washing discarded. This repeated a further three times to ensure complete washing.
4. Blocking is carried out to prevent reactions occurring other than at well sites with 50mg/ml Bovine Serum Albumin (BSA) (in PBS) using flood/fill. 1ml of BSA/PBS is flooded across the sector, pipetted up and down three times, withdrawn and discarded. This allows all wells 76 to be filled simultaneously. Incubate for 15 minutes at room temperature.
5. Wash as before.
6. Primary antibodies are applied to the sector plate 64

-16-

- as a mixture using flood/fill with each individual antibody at the following concentrations: anti-Human Serum Albumin 1/1000, anti-Antitrypsin 1/2000, anti-Macroglobulin 1/2000, anti-Antithrombin III 1/1000, anti-Catalase 1,1000, anti-Antichymotrypsin 1/1000, anti-Plasminogen 1/1000. Antibodies are diluted in 0.5mg/ml BSA/PBS. Incubate for 10 minutes at room temperature.
- 5 7. Wash as before.
 - 10 8. Second antibody is Amdex anti-IgG (peroxidase conjugate) at a concentration of 1/1000 in 0.5 mg/ml BSA/PBS. After washing this is applied to the sector using flood/fill. Incubate at room temperature for 10 minutes.
 - 15 9. Wash as before.
 - 20 10. The substrate is insoluble Tetramethylbenzidine (TMB). This reacts with the peroxidase on the second antibody to produce an intense blue colour. After washing this is applied to the sector plate 64 by flood/fill but is left flooded across the sector plate 64 after pipetting up and down several times. Incubate for 10 minutes at room temperature.
 - 25 11. Remove TMB and discard. Wash out the wells with distilled water four times by flood/fill. A blue precipitate will be evident in wells with a positive reaction. No colour is produced in negative wells. Store sections in dark as TMB will slowly fade in daylight.
- The data for the above assay is shown in Fig. 6a and is graphically represented in Fig. 6b which is reproducible and is representative of a large number of experiments (712).
- 35 It will be seen that there is a significant measurable change for each antibody/antigen reaction compared with the background level. The reaction results in an optical change, from transparent to coloured (blue) and which is measured using an optical detector which measures light

-17-

transmissivity through the disk and wells. In this case optical assessment was carried out using the apparatus as shown in Fig. 5 by locating the plate 64 in a light transmissive microscope 80 (Zeiss Axiophot fitted with a JVC video camera 83 (Model No. TK-1280E)) and sensing the change in optical signal. The output of the video camera is connected to Macintosh IICx 85 with video frame capture. The results can be displayed via the Mac display 87 or a hard copy provided by printer 86. Analysis was carried out by measuring mean grayscale values in centre of wells quantified by NIH Image software. Background levels taken from sectors which had not been exposed to immuno-chemicals or chromogen were subtracted from all experimental wells. Experimental wells contained array or seven separate antigens listed above. In addition, experimental controls were carried out in which specific antigen was omitted wells and wells exposed to the same regime of blocking, antibody binding and exposure to chromogenic substrate. The average reading from these experimental controls minus mean reading from the sector alone was defined as the background level of staining. Experimental readings from the seven specific antigens providing signals of approximately five to six times greater than this background. It will be observed that there is no cross-contamination between wells 76 because of the efficiency of withdrawal and because the substrate in this case is insoluble. However, this assay would also work satisfactorily for soluble substrates because of fluid withdrawal from the sector plate 64 leaving fluid in the wells 76 only, not on surface 64a.

In a modification, if it was unnecessary to withdraw all of the liquid to leave a film on surface 64, the assay would still work with an insoluble substrate in each well; cross-contamination would still not occur. However, this arrangement would be unsatisfactory for soluble substrates in the wells as the film could cause dispersal to other locations and provide contamination of other wells.

With the embodiment shown in Figs. 4a,4b the disk sector plate 54 is more suitable for conducting a variety of different assays, e.g. antigen/antibody assays for different patients, i.e. one patient/sector.

5 It will be appreciated that modifications may be made to the above described embodiments without departing from the scope of the present invention. For example, the opening through which the liquid analyte is introduced may be provided through the lower plate of the multi-well
10 container. More than one opening can be used for faster flooding. This opening may be arranged to receive the tip of a syringe needle. The vent opening may also be provided in any one of the walls of the container although it is preferably provided in a peripheral wall. The opening 22
15 may be provided by a single opening 22 or by a series of openings or vents as shown in Fig. 4d for example. A laser may be used with CD optics instead of the microscope and video camera for the embodiment of Fig. 4. The top plate in the embodiment of Figs. 3 and 4 may be snap-fitted
20 to the lower plate and may be snap-fitted onto a CD base plate which would receive sections and provide the advantage of positioned information. As shown in Fig. 4c the upper planar surface 56 can have sector covers connected to a lower surface or central boss by a hinge,
25 for example an integrated living hinge 90 at the inner radius to allow each disk sector 62 to be pivotably raised and lowered and allow sector plates 64 to be inserted into each sector. The well size and spacing may be varied as required, for example the wells could be 3mm in diameter;
30 1.5mm apart and spaced 5.5mm between centre. The exact size and spacing is a matter of choice consistent with the requirement that fluid is retained in the wells after withdrawal as described above. However, the wells could also be filled during flooding of the space depending on
35 the well size, type of plastic and fluid properties. However, liquid will still be retained in the wells upon withdrawal of the liquid. Also, the structure and inserts

made may be of any suitable optically transmissive plastic, such as polystyrene or perspex (TM). The handle 66 may be integrated with or detachable from plate 64. As shown in Fig. 4a the radially extending ribs may have radial shoulders 92 to define a recess 94 for receiving the plate 64 also defining the spacing height between the surface 64a of the plate 64 and the underside 56a for receiving the liquid. Suitable materials may be used to coat the interior of the sectors to aid fluid movement as described with reference to silicone above. This may be applied to the underside of the top surface and to the top surface of the plate as for the other embodiments. Suitable materials may be used to increase the hydrophobicity of liquid across the sector and hydrophilicity to aid movement of liquid into the desired locations, e.g. wells. The wells may be coated with a suitable optical reflective material to enhance the reflection of light and observation of reactions occurring within the wells and, similarly, lenses may be located in the top or bottom light transmissive plate to improve optical assessment of the reaction. These lenses may be moulded into the upper or lower plates during the manufacture as is well known in plastic moulding processes. Separate optical elements may be used instead, if appropriate.

In a modification to the embodiments described, the wells are absent from the upper surface of the plate and that plate retains its planar surface to enable a thin, uniform layer of liquid to be introduced into the space between the upper disk plate and the insert plate. An insoluble substrate with reagent or reagents (e.g. an antigen) may be applied directly to the planar surface of the insert plate by for example applying spots of reagent thereto.

For certain applications, it may be appropriate to provide each insert with a lid which can be slid into the space between the insert and the upper plate 22 of the disk following filling of the wells. The lower surface of the

lid may be arranged to be flush with the surface of the insert so as to close off each well. This prevents liquid from being thrown out of the wells during spinning of the disk during automated reading and analysis. The invention has use in immunoassay applications including tests for sexually transmitted diseases, parasites, allergens, cancer markers and cardiac markers, either in laboratories or at point-of-care locations, for example medical practitioners offices or the like. Other applications of the invention are in chemical and biochemical assays. Examples of such assays include immunoassay, clinical biochemistry tests, nucleic acid analysis and receptor ligand interactions. Examples of clinical biochemistry uses would be in measurement of serum analytes such as glucose, urea, creatinine and enzymes such as alkaline phosphatase. Immunoassay application include tests designed to detect infectious organisms, viruses, parasites as well as endogenous analytes such as circulating hormone levels and cancer markers. Examples of chemical analysis include measure of phosphate and nitrate levels in water, environmental and industrial monitoring including potable and waste water and process monitoring. The system could be used in a variety of settings including clinical laboratories, doctor's and veterinary surgeries as well as industrial and research laboratories.

CLAIMS

1. A multi-well assay plate structure comprising:
a first upper surface,
a second lower surface having a plurality of wells
disposed therein,
5 the first and second surfaces defining a chamber
having an inlet and an outlet, the inlet and outlet
allowing fluid to be introduced and withdrawn from the
chamber, the wells being proportioned and dimensioned to
retain a volume of fluid in each well following withdrawal
10 of the liquid.
2. An assay plate structure as claimed in claim 1 wherein
the chamber is shallow enough to allow fluid to fill the
wells and the chamber.
3. As assay plate structure as claimed in claim 1 or 2
15 wherein the wells are deep enough to retain a volume of
fluid following withdrawal of fluid in the space above the
wells.
4. As assay plate structure as claimed in any preceding
claim wherein the plate structure is sector-shaped with a
20 handle at the longer arc-portion to facilitate locating the
sector on a disc.
5. An assay plate structure as claimed in claim 4 wherein
a plurality of sector-shaped plate structures are carried
by a disc.
- 25 6. An assay plate structure as claimed in claim 5 wherein
also the sectors and discs are made of plastic and the
sectors can be snap-fitted onto the disc.
7. An assay plate structure as claimed in claim 5 or 6
wherein the sectors and the disc include lock and key
30 portions to allow the sectors to be snap-fitted in the
correct orientation only.
8. As assay plate structure as claimed in any one of
claims 1 to 4 wherein the assay plate structure is a disc
moulded in one piece with a plurality of wells.
- 35 9. An assay plate structure as claimed in claim 8 wherein
the structure includes an upper disc with a plurality of

hinged sectors for allowing the sector to pivot from and return to the plane of the disc to facilitate the insertion and removal of assay plates in the sector space.

5 10. An assay plate structure as claimed in any preceding claim wherein the disk structure has a circumferential gutter extending around its periphery to facilitate collection of fluid following fluid withdrawal from the chamber.

10 11. An assay plate structure as claimed in any preceding claim wherein the plate structure and sector inserts are made of optically transmissive plastic.

15 12. A multi-well assay structure comprising an upper surface and a lower closely spaced opposed surface, said upper and lower surfaces defining a relatively shallow space therebetween, the lower surface having a plurality of wells therein, at least two spaced apart openings providing access to said space from an external location, wherein a fluid introduced into said space through one of said openings substantially fills the space and covers all of
20 the wells and said fluid when subsequently withdrawn through the same or the other opening leaves the wells substantially filled with liquid.

25 13. An assay plate structure as claimed in claim 12 wherein the spacing between said upper and lower surfaces is sufficiently small to facilitate the flow of fluid in said space by capillary or capillary like action.

14. An assay plate structure as claimed in claim 13 wherein the spacing is less than 1mm.

30 15. An assay plate structure as claimed in claim 14 wherein the spacing is less than 0.5mm.

16. An assay plate structure as claimed in claims 13, 14 or 15 wherein the surfaces are provided by respective upper and lower plates which are spaced apart by one or more spacer walls.

35 17. An assay plate structure as claimed in any one of claims 13 to 16 wherein the opening through which fluid is introduced into said space is provided through either the

upper or lower surface.

18. An assay plate structure as claimed in claim 17 wherein the opening is provided through the upper surface.

5 19. An assay plate structure as claimed in any one of claims 13 to 18 wherein said opening for introducing a fluid comprises a relatively small opening arranged to receive the end of a syringe or similar liquid injecting device, where the opening forms a substantially air-tight seal around said end.

10 20. An assay plate structure as claimed in any one of claims 13 to 19 wherein the underside of said upper surface of the container and the upper surface of the plate are treated to increase the hydrophobicity of such surfaces.

15 21. An assay plate structure as claimed in any one of claims 12 to 20 wherein the multi-well structure is a disk which comprises upper and lower circular plates, the internal surfaces of which respectively define said upper and lower opposed surfaces.

20 22. An assay plate structure as claimed in claim 21 wherein the second opening is provided at the peripheral edge of the disc.

25 23. An assay plate structure as claimed in claim 21 or 22 wherein the space between the upper and lower plates is subdivided, by one or more dividing walls, to provide a plurality of multi-well plates in which case each space is provided with an opening and a vent to enable each space to be independently filled.

24. An assay plate structure as claimed in claim 23 wherein the dividing walls are radially extending.

30 25. An assay plate structure as claimed in any one of claims 21 to 24 wherein at least one of the upper and lower plates forming the structure are transparent to enable optical inspection of the wells from outside the structure.

35 26. An assay plate structure as claimed in claim 24 wherein the other of the upper and lower plates may comprise a reflecting surface so that radiation entering into the structure through the transparent plate

transverses the structure in both directions for providing improved signal detection.

27. An assay plate structure as claimed in any one of claims 12 to 20 wherein there is provided a disc arranged to receive a plurality of sector-shaped inserts each of which comprises a generally planar upper surface having a plurality of wells provided therein, the disk having, for each insert, a substantially planar surface arranged, in use, to oppose said substantially planar insert surface and means for retaining the insert in position so that the respective planar surfaces are in a closely spaced arrangement to one another, and to said at least two openings.

28. An assay plate structure as claimed in claim 27 wherein the opening for filling the space is provided through the planar surface of the disc.

29. An assay plate structure as claimed in claim 27 or 28 wherein the vent opening is provided at, or adjacent to, the peripheral edge of the disc.

30. An assay plate structure as claimed in claims 27 to 29 wherein the disc comprises upper and lower circular plates separated by radially extending spacers.

31. An assay plate structure as claimed in claim 30 wherein said planar surface of each insert comprises upstanding walls around at least a portion of its periphery for the purpose of sealing the inner edges of the insert to the opposed planar surface of the disc, thereby to prevent seepage of liquid around the insert.

32. A method of filling the wells of the multi-well structure of the above first aspect of the present invention, said method comprising the steps of:

introducing a fluid into said chamber through one of said openings to substantially flood the chamber;

and subsequently withdrawing the fluid from the chamber through the same or the other opening to leave liquid in the wells.

33. A method as claimed in claim 8 wherein the method

further includes the step of forming an air tight seal between the fluid inlet and an end region of a syringe or similar liquid injecting device, and injecting fluid through the opening into the chamber and subsequently sucking liquid out of the space through the opening.

5 34. A method conducting a chemical or biochemical assay said method comprising the steps of:

10 providing a surface within a substantially enclosed chamber having a plurality of wells at spaced locations sufficient to allow monitoring of a reaction at each well location,

treating each well with a first reagent, flooding the enclosed chamber and covering the wells with a fluid carrying at least a second reagent,

15 removing excess fluid from said chamber to leave a mixture of said first and second reagents in each well, and

20 optically assessing each well and determining if a reaction occurred and correlating the reaction results to provide an assay of the chemical or biochemical reactions under test.

35. A method as claimed in claim 34 wherein the step of optical assessment is carried out automatically using optical reading apparatus.

25 36. A method as claimed in claim 34 or 35 wherein the surfaces with wells having the first fluid carrying reagents are prior prepared for loading into the structure.

30 37. A method as claimed in any one of claims 34 to 36 wherein after optical assessment of the results of the assay, the automated fluid handling apparatus is used to inject and withdraw rinsing fluid a predetermined number of times from the well tray to clean the wells for receiving subsequent samples for assay.

35 38. Chemical/biochemical assay apparatus comprising an assay plate structure defined in said first aspect and having a plurality of wells for receiving samples to be assayed,

fluid handling means for introducing and removing

fluid reagents into said assay plate structure to allow a fluid reagent mixture to be retained in each well, and

optical assessment means for measuring optical result of the reaction in each well.

5 39. An assay plate structure for use in conducting optical assays of a fluid analyte, the plate structure comprising:

10 a disc for rotation about a central axis, the disc having upper and lower plates and a plurality of substantially radially extending walls disposed between the plate, wherein said walls sub-divide the disc into a plurality of disc sectors; and

a plurality of disc inserts arranged to be received by respective disk sectors and to be retained therein,

15 the structure further a plurality of openings through the upper surface, at least one opening above each disc sector for introducing a liquid analyte into the sector space between the plate and the disc insert.

20 40. An assay plate structure as claimed in claim 39 wherein the disc further comprises a lower plate, spaced apart from said upper plate by said radially extending walls.

41. An assay plate structure as claimed in claim 40 wherein the upper surface of each disc insert and the opposed surface of the plate are substantially planar.

25 42. An assay plate structure as claimed in any one of claims 39 to 41 wherein a vent opening is provided for each disc segment around the periphery thereof, between the radially outer edge of the upper plate and each disc insert.

30 43. A multi-sample assay plate structure comprising:

a first upper surface,

a second lower surface spaced from the upper surface by wall means to define a chamber with the upper and lower surfaces spaced a preset distance apart,

35 the chamber having an inlet and an outlet, the inlet and outlet allowing fluid to be introduced to, and withdrawn from, the chamber, the lower surface being

adapted to receive spots of an insoluble substrate, carrying a first reagent, or no reagent if a control spot, to create a plurality of separate reaction sites, such at least a reagent is present in the fluid for reacting with the first reagent to create an observable reaction in the chamber.

5 44. A method of conducting an assay using the structure of claim 43 including the steps of,
10 disposing a plurality of spots of an insoluble substrate on said lower surface a predetermined distance apart to create a plurality of reaction sites, said spots carrying a first reagent, or none if a control spot,
15 flooding the chamber with fluid carrying at least one second reagent, withdrawing the fluid from the chamber to leave sufficient spots of fluid in contact with the substrate spots, and
optically monitoring each spot location to detect a reaction.

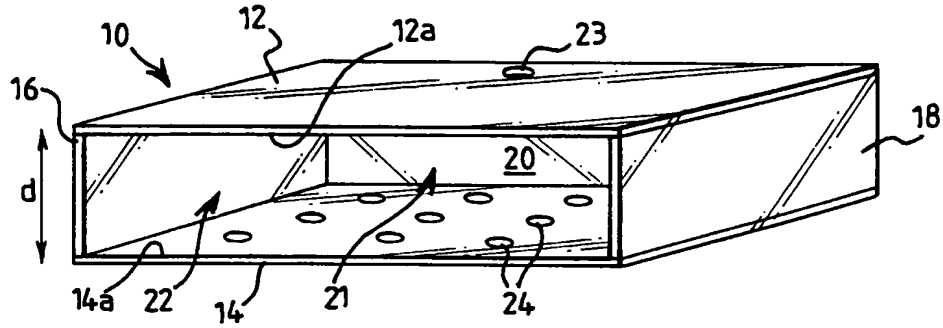

FIG. 1

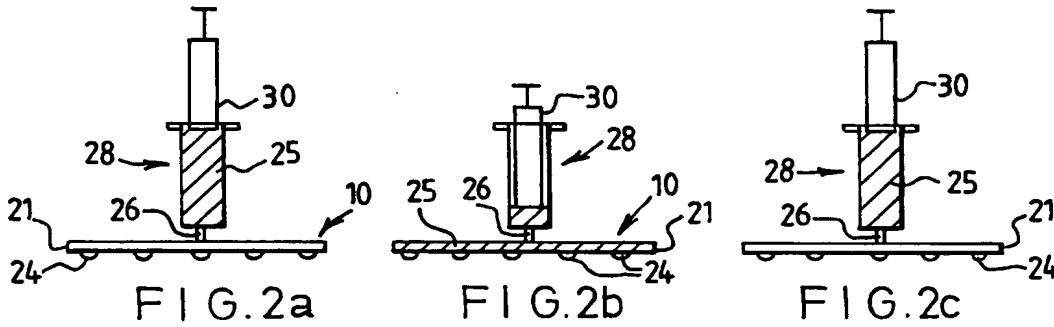

FIG. 2a

FIG. 2b

FIG. 2c

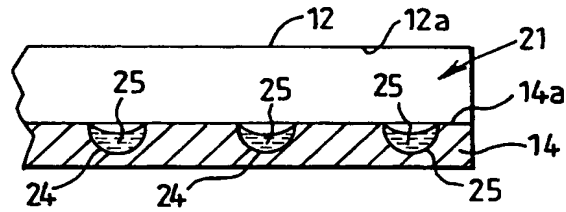

FIG. 2d

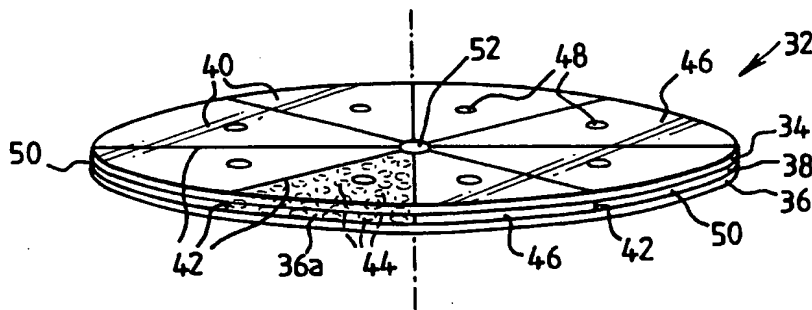

FIG. 3

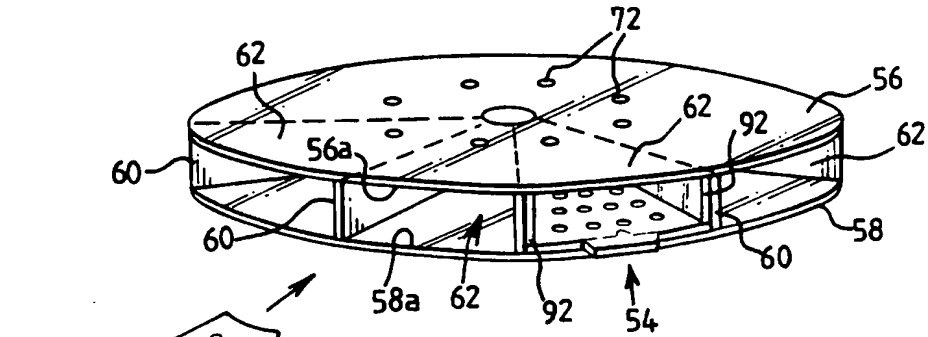

FIG. 4a

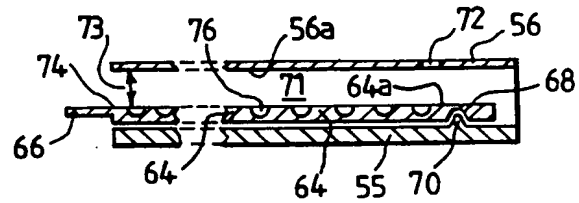
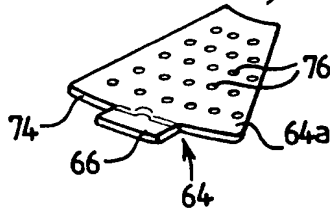

FIG. 4b

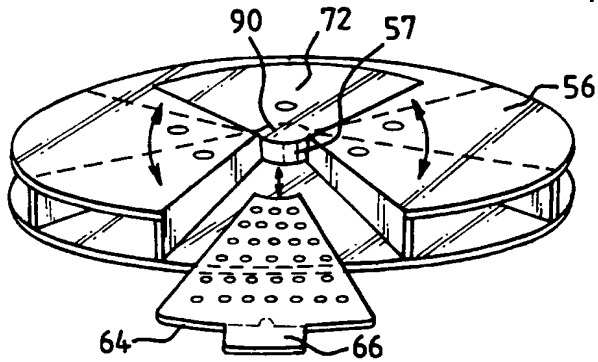

FIG. 4c

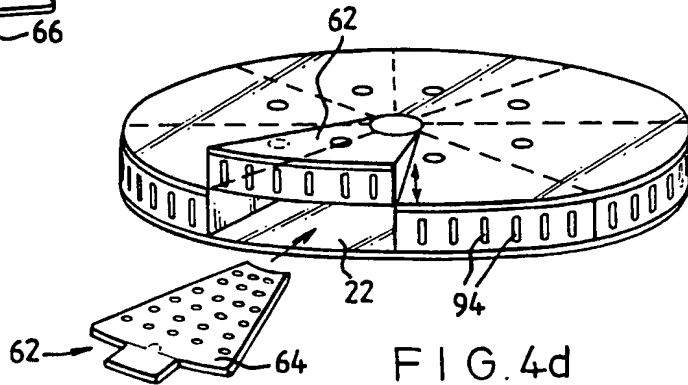

FIG. 4d

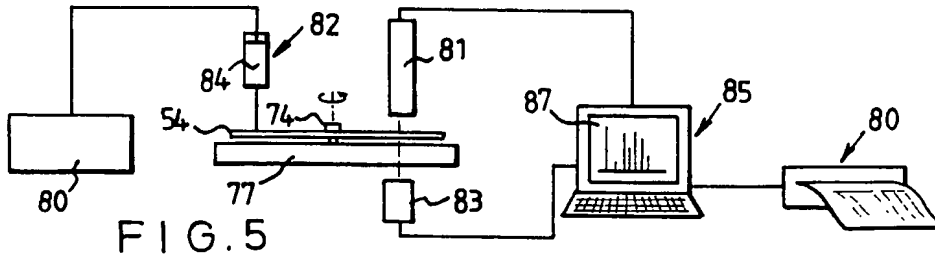
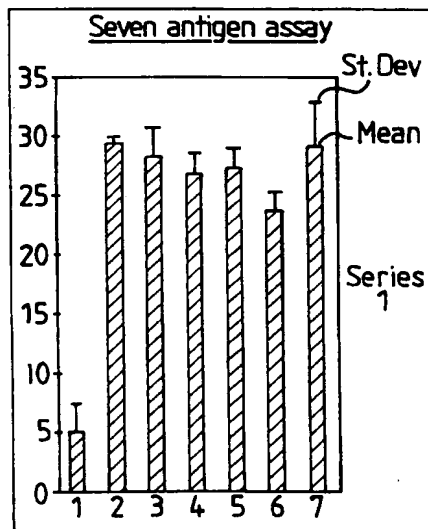

FIG. 5

Data	Clear plastic	Clear plastic + Blue reaction agent		Seven antigen assay					
	↓	+Blocking agent							
	76.4	80.2	106.6	108.8	103.3	103.4	102.2	103.6	108.8
	76.4	85.5	106.4	103.9	101.3	102.7	98.5	111.2	109
	76.83	81.4	105.4	103.1	105.2	104.2	101	106.2	109.5
	74.53	81.6	106.5	104.7	104.7	106.4	100.7	102.9	106.4
	78.62	82.6							
	76.75	79.6							
	77.6	78.9							
	77.8	833							
<u>Mean-bkgd</u>		5	29.4	28.3	26.9	27.4	23.8	292	31.6
<u>St.Dev</u>	0.56	2.44	0.56	2.44	1.75	1.60	1.54	3.76	1.38

FIG. 6a



Key
 1 = Background
 2 = Human serum albumin
 3 = Antitrypsin
 4 = Macroglobulin
 5 = Antithrombin III
 6 = Catalase
 7 = Antichymotrypsin

FIG. 6b

INTERNATIONAL SEARCH REPORT

national Application No
PCT/GB 97/02708

A. CLASSIFICATION OF SUBJECT MATTER IPC 6 B01L3/00 G01N33/543				
According to International Patent Classification(IPC) or to both national classification and IPC				
B. FIELDS SEARCHED Minimum documentation searched (classification system followed by classification symbols) IPC 6 B01L G01N				
Documentation searched other than minimum documentation to the extent that such documents are included in the fields searched				
Electronic data base consulted during the international search (name of data base and, where practical, search terms used)				
C. DOCUMENTS CONSIDERED TO BE RELEVANT				
Category *	Citation of document, with indication, where appropriate, of the relevant passages	Relevant to claim No.		
X	EP 0 430 248 A (MOCHIDA PHARM CO LTD) 5 June 1991 see page 3, line 34-38 see page 11, line 10 - page 13, line 8; figures 17,18 ---	43,44		
A	US 5 424 036 A (USHIKUBO MASAO) 13 June 1995 see column 4, line 57 - column 5, line 52; figures 2,4,5 ---	39		
A	US 5 281 540 A (MERKH CARL W ET AL) 25 January 1994 see column 4, line 34-68 see column 6, line 15-47 see column 9, line 50-61; figures 1,2,5 --- -/--	39		
<input checked="" type="checkbox"/> Further documents are listed in the continuation of box C. <input checked="" type="checkbox"/> Patent family members are listed in annex.				
* Special categories of cited documents :				
<table style="width: 100%; border: none;"> <tr> <td style="width: 50%; border: none; vertical-align: top;"> "A" document defining the general state of the art which is not considered to be of particular relevance "E" earlier document but published on or after the international filing date "L" document which may throw doubts on priority claim(s) or which is cited to establish the publication date of another citation or other special reason (as specified) "O" document referring to an oral disclosure, use, exhibition or other means "P" document published prior to the international filing date but later than the priority date claimed </td> <td style="width: 50%; border: none; vertical-align: top;"> "T" later document published after the international filing date or priority date and not in conflict with the application but cited to understand the principle or theory underlying the invention "X" document of particular relevance; the claimed invention cannot be considered novel or cannot be considered to involve an inventive step when the document is taken alone "Y" document of particular relevance; the claimed invention cannot be considered to involve an inventive step when the document is combined with one or more other such documents, such combination being obvious to a person skilled in the art. "&" document member of the same patent family </td> </tr> </table>			"A" document defining the general state of the art which is not considered to be of particular relevance "E" earlier document but published on or after the international filing date "L" document which may throw doubts on priority claim(s) or which is cited to establish the publication date of another citation or other special reason (as specified) "O" document referring to an oral disclosure, use, exhibition or other means "P" document published prior to the international filing date but later than the priority date claimed	"T" later document published after the international filing date or priority date and not in conflict with the application but cited to understand the principle or theory underlying the invention "X" document of particular relevance; the claimed invention cannot be considered novel or cannot be considered to involve an inventive step when the document is taken alone "Y" document of particular relevance; the claimed invention cannot be considered to involve an inventive step when the document is combined with one or more other such documents, such combination being obvious to a person skilled in the art. "&" document member of the same patent family
"A" document defining the general state of the art which is not considered to be of particular relevance "E" earlier document but published on or after the international filing date "L" document which may throw doubts on priority claim(s) or which is cited to establish the publication date of another citation or other special reason (as specified) "O" document referring to an oral disclosure, use, exhibition or other means "P" document published prior to the international filing date but later than the priority date claimed	"T" later document published after the international filing date or priority date and not in conflict with the application but cited to understand the principle or theory underlying the invention "X" document of particular relevance; the claimed invention cannot be considered novel or cannot be considered to involve an inventive step when the document is taken alone "Y" document of particular relevance; the claimed invention cannot be considered to involve an inventive step when the document is combined with one or more other such documents, such combination being obvious to a person skilled in the art. "&" document member of the same patent family			
Date of the actual completion of the international search	Date of mailing of the international search report			
27 February 1998	10/03/1998			
Name and mailing address of the ISA European Patent Office, P.B. 5818 Patentlaan 2 NL - 2280 HV Rijswijk Tel. (+31-70) 340-2040, Tx. 31 651 epo nl, Fax: (+31-70) 340-3016	Authorized officer Zinngrebe, U			

INTERNATIONAL SEARCH REPORT

International Application No
PCT/GB 97/02708

C.(Continuation) DOCUMENTS CONSIDERED TO BE RELEVANT		
Category	Citation of document, with indication, where appropriate, of the relevant passages	Relevant to claim No.
A	US 4 077 845 A (JOHNSON LEIGHTON CLIFFORD) 7 March 1978 see column 6, line 3-18 see column 6, line 23-47 ---	1, 12, 32, 34, 38
A	US 4 195 060 A (TERK HAROLD S) 25 March 1980 see column 3, line 5-68 ---	1, 12, 32, 34, 38
A	GB 1 572 596 A (OPTO ELECTRONIC DISPLAYS LTD) 30 July 1980 see page 2, line 43-109; figure 1 ---	1, 12, 32, 34, 38
A	US 5 338 666 A (MONTHONY JAMES F ET AL) 16 August 1994 see column 6, line 55 - column 7, line 9 see column 7, line 30-66 -----	1, 12, 32, 34, 38

INTERNATIONAL SEARCH REPORT

Information on patent family members

International Application No PCT/GB 97/02708

Patent document cited in search report	Publication date	Patent family member(s)	Publication date
EP 0430248 A	05-06-91	AU 642444 B	21-10-93
		AU 6702690 A	06-06-91
		CA 2031001 A	31-05-91
		JP 3223674 A	02-10-91
		US 5147607 A	15-09-92
US 5424036 A	13-06-95	JP 5297007 A	12-11-93
		DE 4313399 A	28-10-93
US 5281540 A	25-01-94	US 5075077 A	24-12-91
		CA 2123785 A	23-05-93
		EP 0649534 A	26-04-95
		JP 7501149 T	02-02-95
		WO 9310454 A	27-05-93
		AT 137025 T	15-05-96
		AU 625064 B	02-07-92
		AU 3884889 A	08-02-90
		CA 1335345 A	25-04-95
		DE 68926272 D	23-05-96
		DE 68926272 T	19-12-96
		EP 0353590 A	07-02-90
		ES 2088878 T	01-10-96
JP 2075954 A	15-03-90		
US 4077845 A	07-03-78	AU 504980 B	01-11-79
		AU 3145577 A	21-06-79
		CA 1090239 A	25-11-80
		DE 2817145 A	26-10-78
		FR 2388046 A	17-11-78
		GB 1548530 A	18-07-79
		JP 1130914 C	17-01-83
		JP 53144186 A	15-12-78
		JP 57024749 B	26-05-82
US 4195060 A	25-03-80	US 4178345 A	11-12-79
		AU 522647 B	17-06-82
		AU 4388879 A	16-08-79
		CA 1122890 A	04-05-82
		DE 2904597 A	30-08-79
		DK 50879 A,B,	09-08-79

INTERNATIONAL SEARCH REPORT

Information on patent family members

International Application No

PCT/GB 97/02708

Patent document cited in search report	Publication date	Patent family member(s)	Publication date
US 4195060 A		FR 2417109 A	07-09-79
		GB 2014307 A,B	22-08-79
		JP 1164381 C	26-08-83
		JP 54115187 A	07-09-79
		JP 57054746 B	19-11-82
		NL 7900987 A	10-08-79
		SE 448029 B	12-01-87
		SE 7900854 A	09-08-79
		BE 874007 A	07-08-79
		ZA 7900376 A	30-01-80

GB 1572596 A	30-07-80	NONE	

US 5338666 A	16-08-94	US 5182082 A	26-01-93
		AT 137798 T	15-05-96
		AU 640838 B	02-09-93
		AU 8965791 A	30-07-92
		DE 69210424 D	13-06-96
		DE 69210424 T	05-12-96
		EP 0496200 A	29-07-92
		ES 2086556 T	01-07-96
		JP 2096899 C	02-10-96
		JP 4315946 A	06-11-92
JP 8012135 B	07-02-96		
NZ 240604 A	27-06-94		
